

Type A
Without Segments

Date _____

Vessel _____

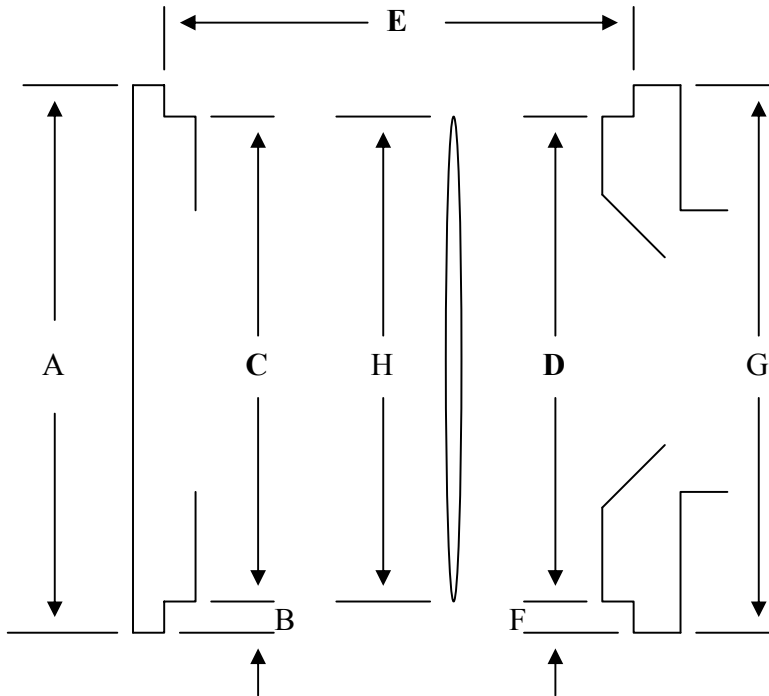

A. _____ mm

B. _____

C. _____

D. _____

E. _____

F. _____

G. _____

H. _____

- Note:**
1. Dimensions **C, D & E** are the most important.
 2. Please measure large diameters by the circumference and calculate the diameter. (Diameter= Circumference x 7/22)
 3. Dimensions **C & D** are often different.
 4. H is the diameter of the diffuser plates if fitted.
 5. Filter thickness is 35mm, check that the filter will clear all adjacent flanges & pipework. Split filters can be made when necessary.

Engine make & model _____

Bore _____

Stroke _____

No. Cyls _____

RPM _____

Boost Press _____

T/C builder & model _____

Number of T/C's per Engine _____

T/C Uniformity: check are they all the same?? _____

Check Access to E/rm, size of hatches etc. _____

Type B
Segmented Filter Type

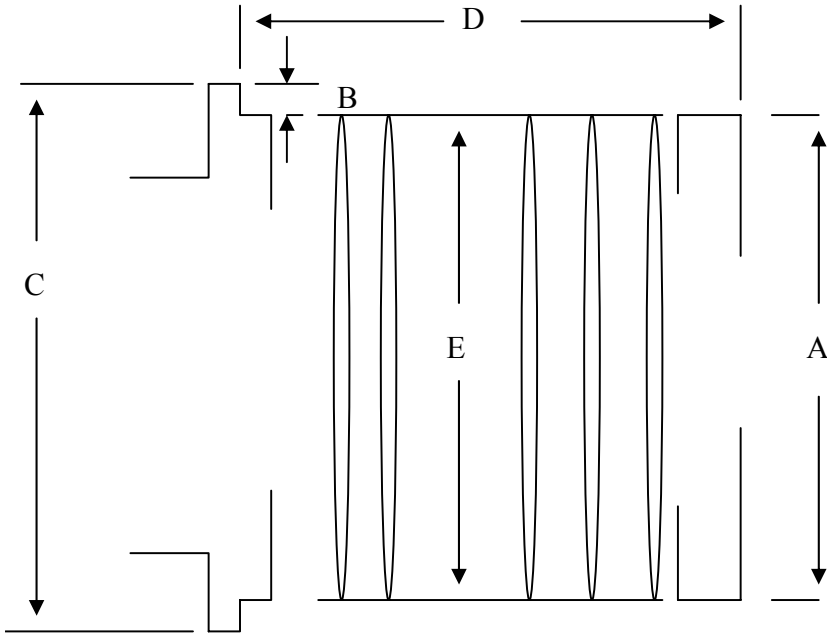

Date _____

Vessel _____

A. _____

B. _____

C. _____

D. _____

E. _____

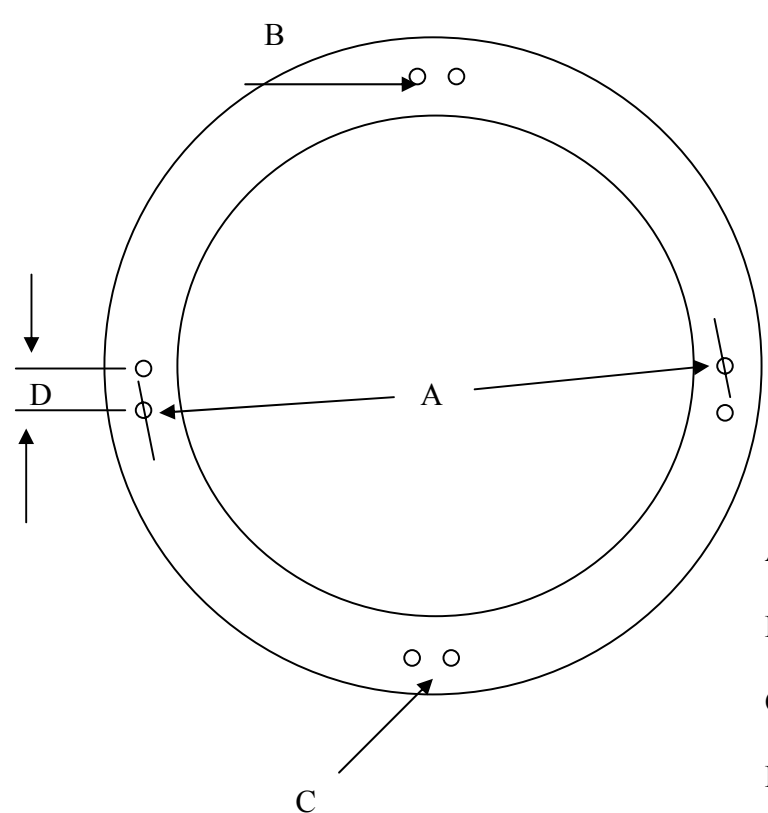

A. PCD _____

B. Thread size and depth _____

C. Thread Qty _____

D. Distance between studs _____